

Two-piece Boom

Compact machine body, but wide working range

- Working reach is about 20% longer than that with the standard front (when the upper boom cylinder is extended to the maximum).
- Long working reach ensures efficient demolition of tall buildings over a fence.
- Suitable for light-duty jobs such as grading and scraping rubbles together.

● Working Range Diagram ●

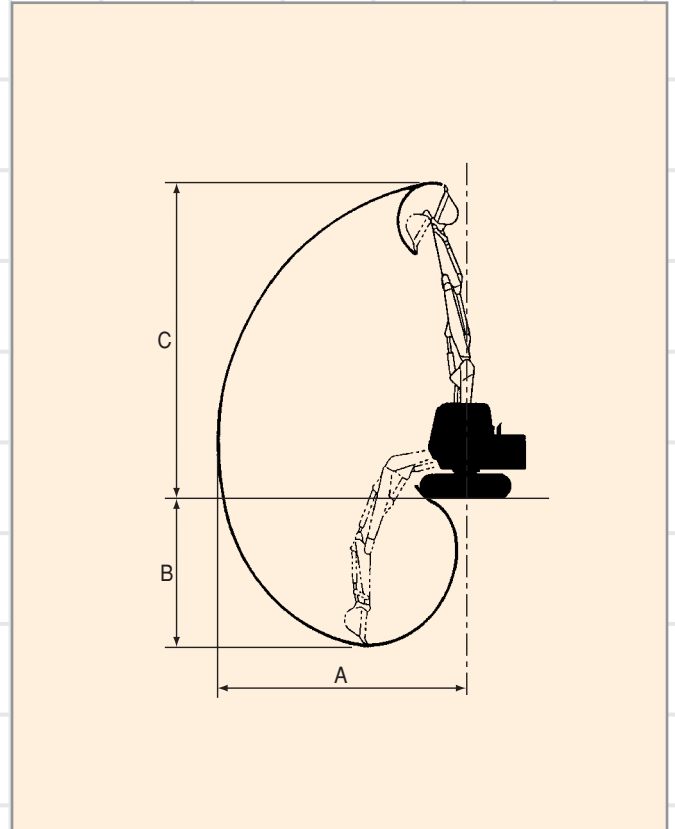

● Specifications ●

| Applicable Models | ZAXIS75US-A | ZAXIS80LCK | ZAXIS130K | ZAXIS135USK |
|-------------------------------|---------------------|------------|-----------|-------------|
| Type | TB75-A | TB70 | TB120 | TB135 |
| Overall length | mm 5 955 | 6 160 | 7 800 | 7 490 |
| Overall height | mm 2 700 | 2 700 | 2 960 | 2 970 |
| Bucket capacity (PCSA heaped) | m ³ 0.28 | 0.28 | 0.50 | 0.5 |
| Operating weight | kg 8 000 | 7 500 | 13 500 | 14 300 |

● Working Range ●

| Applicable Models | ZAXIS75US-A | ZAXIS80LCK | ZAXIS130K | ZAXIS135USK |
|-------------------|----------------|-------------|--------------|--------------|
| A Digging reach* | mm 7 595/6 510 | 7 490/6 400 | 9 210/8 390 | 9 240/8 420 |
| B Digging depth | mm 4 220 | 4 280 | 5 590 | 5 550 |
| C Cutting height* | mm 8 830/6 030 | 8 760/5 970 | 10 400/8 650 | 10 500/8 750 |

<Notes> ● * Value when upper boom cylinder is extended to the maximum.
 ● Backhoe is restricted to application to light-duty job.