

Tunnel Machine

Various attachments can be mounted for tunneling through a mountain and for underground work

- Purpose designed machines fitted with black smoke purifier (ceramic muffler) for operation in tunnel.
- Mountable attachments include loading shovel front, short-reach front, breaker, loading bucket, and twin header.
- A “non-electronic control” version is available to prevent the trouble by waterdrop etc.

● Example of Equipment/Accessories ●

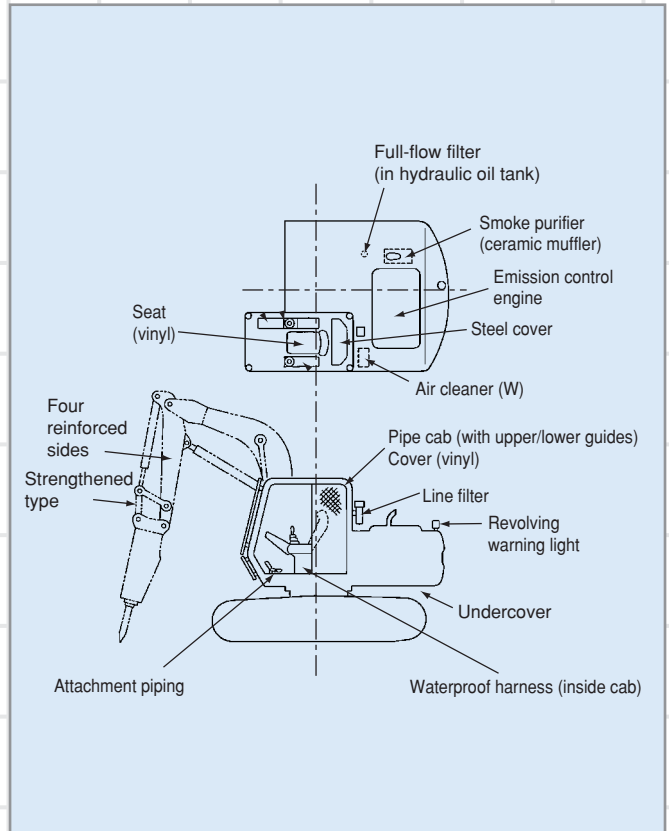

● Specifications ●

Applicable Models	kgAXIS135USTN		kgAXIS160LCTN		kgAXIS225USTN kgAXIS225US(LC) TN		kgAXIS230 (LC) TN		
	Std.	Short reach	Std.	Short reach	Std.	Short reach	Std.	Short reach loader*	
Front type									
Max. working radius	mm	8 300	6 640	8 960	7 680	10 010	7 700	10 400	9 460
Maximum digging depth	mm	5 530	2 900	6 190	4 460	6 790	4 290	6 660	4 890
Maximum cutting height	mm	9 220	7 610	9 710	9 080	11 100	8 460	9 900	10 610
Maximum dumping height	mm	6 760	5 180	6 900	6 240	8 190	5 570	7 030	—
Minimum swing radius	mm	2 060	2 490	2 270	2 580	2 300	3 450	4 010	2 290
Overall transport length	mm	7 290	5 680	8 110	6 360	8 920 (9 060)	6920 (7 060)	9 700	4 940
Transport height	mm	2 840	2 740	2 840	3 100	2 800 (2 990)	3 170	3 210	3 120
Rear-end swing radius	mm	1 465	1 465	1 750	1 750	1 680	1 680	1 780	1 780
Bucket capacity (PCSA heaped)	m ³	0.5	0.5	0.7	0.7	0.8	0.8	1.0	—
Operating weight	kg	13 200	13 200	18 010	18 200	23 000 (23 500)	23 200 (23 700)	29 500	35 800

<Notes> ● For more details of loader front and others, contact Hitachi.

- The model TN is provided with the smoke purifier as standard equipment.