

Sliding Arm (Standard type)

For digging deeper with a longer reach

- Light structure and easy operation.
- Simple structure results in easy maintenance.
- Advanced cross-support structure reduces machine jolts.



● Working Range Diagram ●

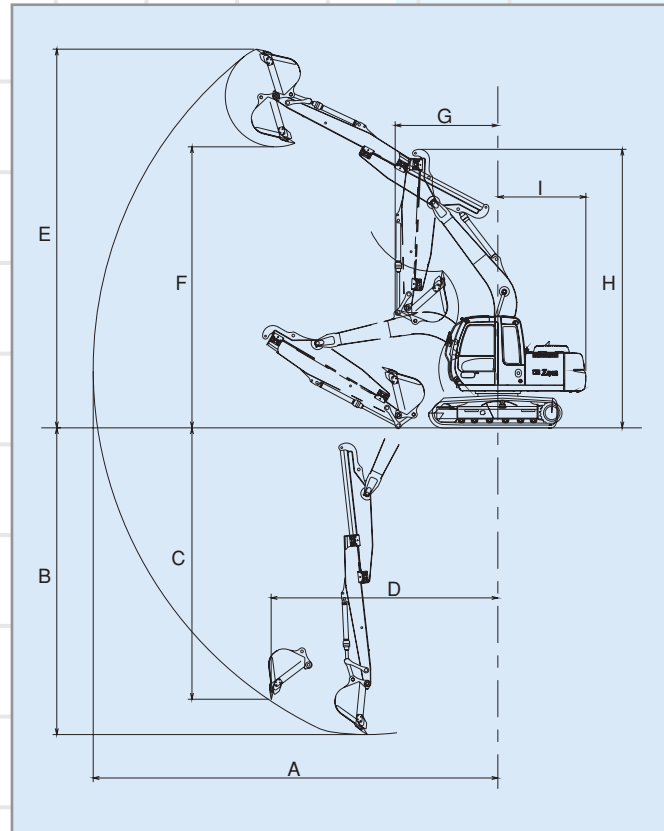

● Specifications ●

Applicable Models	ZAXIS70	ZAXIS75US-A	ZAXIS110	ZAXIS125US	ZAXIS120	ZAXIS135US	ZAXIS200	ZAXIS225USR	ZAXIS225US	ZAXIS125W	
Type	SA60	SA60	SA100	SA100	SA120	SA120	SA200	SA200	SA-200	SA-100	
Arm sliding length	mm 1 770	mm 1 770	mm 2 000	mm 2 000	mm 2 000	mm 2 000	mm 2 300	mm 2 300	mm 2 300	mm 2 000	
Operating weight	kg 7 030	kg 7 990	kg 11 600	kg 13 400	kg 13 200	kg 14 640	kg 21 400	kg 23 000	kg 24 400	kg 13 800	
Bucket capacity (PCSA heaped)	m ³ 0.19	m ³ 0.23	m ³ 0.3	m ³ 0.3	m ³ 0.4	m ³ 0.4	m ³ 0.51	m ³ 0.51	m ³ 0.51	m ³ 0.3	
Working range	A Max. digging reach	mm 8 530	mm 8 630	mm 9 800	mm 10 140	mm 10 300	mm 10 360	mm 12 200	mm 12 240	mm 12 340	mm 9 850
	B Max. digging depth	mm 6 660	mm 6 580	mm 8 420	mm 7 620	mm 7 870	mm 7 840	mm 9 380	mm 9 390	mm 9 510	mm 7 100
	C Max. vertical wall	mm 5 790	mm 5 460	mm 6 570	mm 6 760	mm 6 780	mm 6 780	mm 8 100	mm 8 100	mm 7 970	mm 5 910
	D Max. vertical digging reach	mm 4 520	mm 5 010	mm 5 490	mm 5 720	mm 6 130	mm 6 090	mm 7 050	mm 7 060	mm 7 060	mm 5 860
	E Max. cutting height	mm 8 430	mm 8 480	mm 9 170	mm 10 480	mm 9 600	mm 10 650	mm 10 100	mm 10 190	mm 12 500	mm 10 750
	F Max. dumping height	mm 6 380	mm 6 450	mm 6 800	mm 8 040	mm 7 240	mm 8 220	mm 7 460	mm 7 460	mm 9 620	mm 8 320
	G Min. front swing radius	mm 2 140	mm 2 260	mm 2 490	mm 2 270	mm 2 600	mm 2 230	mm 3 810	mm 3 810	mm 2 400	mm 1 990
H Height at min. front swing radius	mm 6 200	mm 6 260	mm 6 740	mm 7 360	mm 7 030	mm 7 360	mm 8 200	mm 8 200	mm 9 090	mm 7 690	
I Rear-end swing radius	mm 1 750	mm 1 240	mm 2 130	mm 1 465	mm 2 130	mm 1 510	mm 2 750	mm 1 990	mm 1 680	mm 1 740	
Overall length at transport	mm 6 730	mm 6 410	mm 7 830	mm 7 880	mm 8 190	mm 7 880	mm 10 200	mm 9 540	mm 9 720	mm 7 830	
Overall height at transport	mm 2 600	mm 2 680	mm 2 940	mm 2 900	mm 2 910	mm 2 920	mm 3 030	mm 3 030	mm 3 020	mm 3 750	

<Note> Do not operate the heavy-duty excavation with sliding arm.