

Two-Axis Shearing/Shredding Bucket

Multiple operations: scooping-up, shredding and loading

- Fitted with large two-axis shear with 760 mm axial length and 300 mm cutter diameter.
- Handling various wastes, including household electrical appliances and tires.
- Pedal control of rotational direction for efficient shearing.



● Dimensions ●

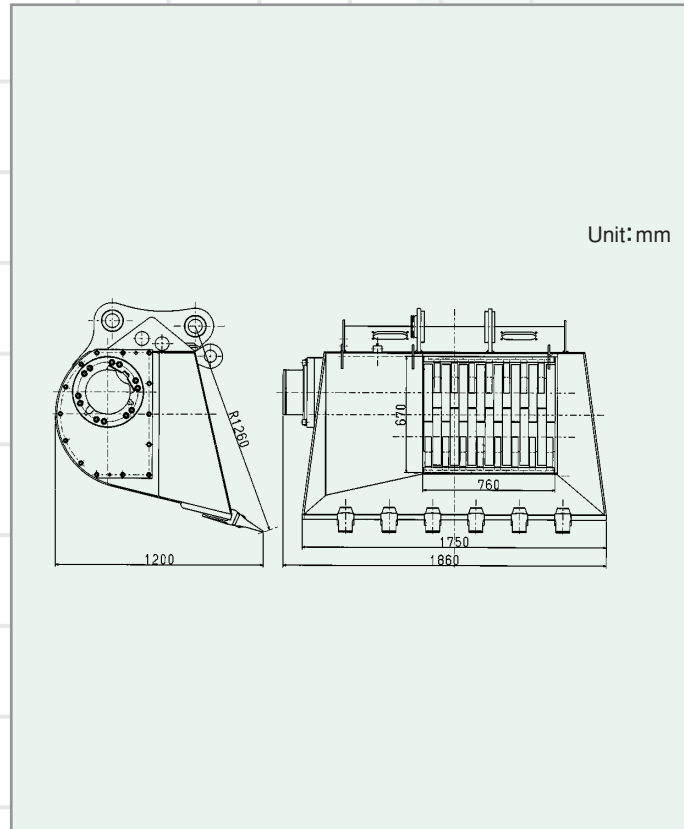

● Specifications ●

Applicable Models		kgAXIS200LC
Type		2-axis shearing/shredding
Operating weight	kg	2 400
Bucket opening dimension	mm	1 730×930
Shredder opening dimension	mm	760×670
Cutter speed	min ⁻¹ (rpm)	24 (24)
Shearing torque	N·m (kgf·m)	30 000 (3 060)

<Notes> ● Data shown above are in SI units, followed by data in conventional units in ().
 ● Exclusive attachment piping and weighted counterweight are required.