

Scrap Handling Machine

Mobile capability for high-efficiency operations

- Long arm and boom mounted for wider working ranges and increased work efficiency.
- The fork grapple, orange-peel grapple, and magnet can be mounted on the machine fitted with bucket cylinder. Machine modification is required before using the magnet.
- Height of the high cab can be optionally adjusted according to job needs.

● Working Range Diagram ●

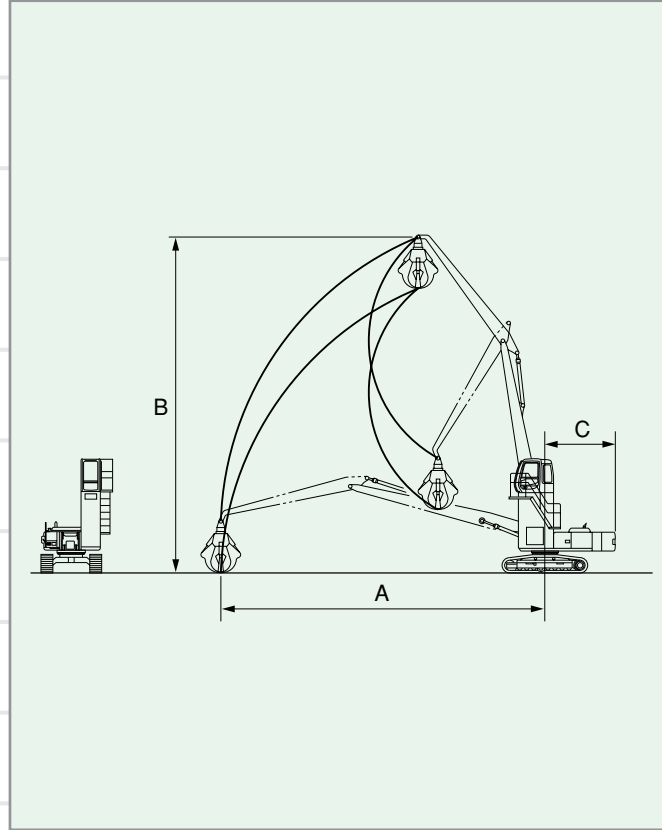

● Specifications ●

Applicable Models		ZAXIS230LC	ZAXIS330LC	ZAXIS450LC	
Type		SC220	SC300	SC400	
Grappling capacity		kg	2 000	2 200	2 900
A	Max. working height	mm	14 000	15 300	16 800
B	Max. working radius	mm	12 000	14 000	16 000
C	Rear-end swing radius	mm	3 210	3 730	3 830
Operating weight		kg	29 000	36 800	51 900

<Note> Some models other than the above are applicable.