

Joint Cutter Machine

Exclusively for patching side joint plates to dam body

- It is possible to strike side joint plates vertically against a dam body using a vibrating slide bracket, ensuring efficient work.



Model:EX100

● Working Range Diagram ●

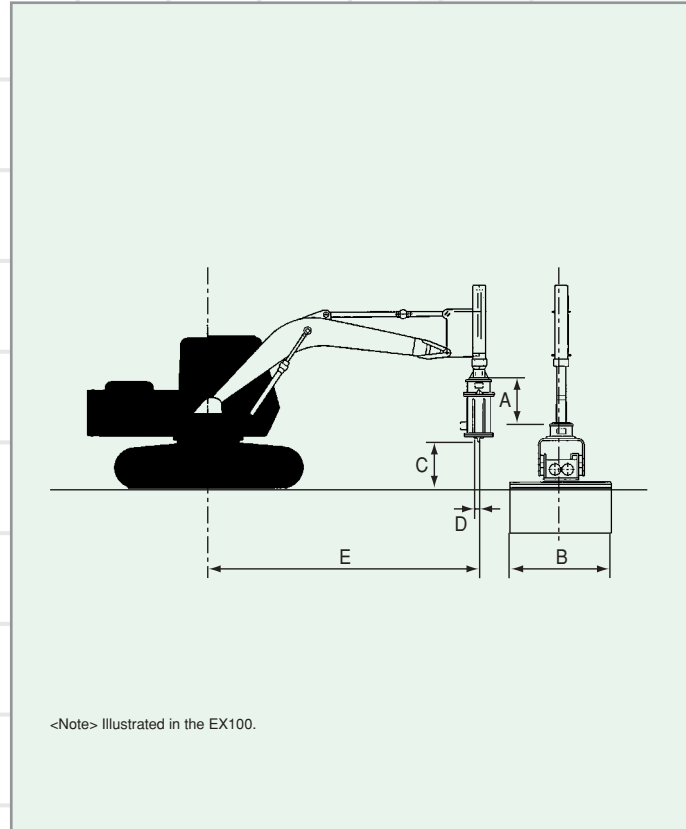

● Specifications ●

Applicable Models	kgAXIS70	kgAXIS110
Type	NPK/HP913-A	NPK/HP913-C
Operating weight	kg	kg
	Approx. 8 500	Approx. 12 500
Number of vibration	c.p.m.	c.p.m.
	0 to 2 700	0 to 2 800
Vibration generating force	tf	tf
	0 to 13.1	0 to 16
Oscillation	mm	mm
	3 to 4	3 to 4

● Working Range ●

Applicable Models	kgAXIS70	kgAXIS110		
A	Slide stroke	mm	900	1 100
B	Blade width	mm	1 000	1 200
C	Blade height*	mm	800	900
D	Blade thickness	mm	16	16
E	Max. working radius	mm	4 180	4 780

<Note> * Effective cutting depth